

SUPERCRITICAL FLUID CO₂ EXTRACTION ON LICHEN

Usnea barbata L.

Kiril Lisichkov, Stefan Kuvendziev

klisickov@yahoo.com

*Faculty of Technology and Metallurgy, University "Ss. Cyril and Methodius",
Skopje, R. Macedonia*

Abstract

*Non-conventional separation procedure - supercritical fluid CO₂ extraction (SFE-CO₂) conforms to the strict demands of the precise process eco-technologies. It represents a perspective method especially in obtaining eco-friendly extracts from vegetable and animal raw materials. The influence of operating parameters (raw material' granulation, extraction fluid' flow rate, operating pressure, operating temperature and extraction time) on the yield of extract and usnic acid, has been studied throughout the extraction process on *Usnea barbata L.*, by application of supercritical CO₂ (SFE-CO₂). The separation process in all experiments was conducted at operating temperature of 25 °C and operating pressure of 50-55 bar. The extraction of active components from the lichens by supercritical CO₂ was performed in a high-pressure, extraction "pilot-plant" for processing solid raw materials.*

Keywords: *SFE-CO₂, usnic acid, lichen.*

1. INTRODUCTION

The lichens are lower tallow phytogenic herbs and represent a symbiosis between algae and fungi. The lichens vegetate on different substratum as: ground, branches, different kind of trunks, stones even on big rocks. The talus of lichens is different by size, shape and color depending of appearance and family to which belongs [1,2].

The lichens – symbiotic organisms from fungi and algae consist of huge number of organic compounds, so-called lichen's substances that are more or less typical for that group of cryptogames [3,4].

The lichens consists many different chemical compounds as: amino acids derivatives, sugar alcohols, aliphatic acids γ -, δ - and macrocyclic lactones, mono cyclic aromatic compounds, quinines, chromones, xanthones, dibenzofuranes, depsides, depsidones, depsones, terpenoids, steroids and carotenoids [1,5].

In the recent years, there has been growing interest in supercritical fluid extraction in chemical, pharmaceutical, cosmetical, food industry and medicine. The term supercritical refers to the fact that the solvent is at a temperature above or near its vapour – liquid critical point. Thus the solvent or fluid cannot be liquefied by increasing the pressure. Under these conditions the properties of supercritical fluids are unusual. Supercritical fluids have densities greater than those of gases but rather comparable to those of liquid. The viscosity and diffusivity values are intermediate between liquids and gases.

Thus, supercritical fluids are solvent power like liquids with mass transfer characteristics like gases. The solvent power can be varied over a wide range by varying the pressure or temperature. The extract can be separated by precipitation or condensation from supercritical fluid by varying the temperature and pressure [9,10].

The most commonly used supercritical fluid is carbon dioxide. It has advantages over other supercritical solvents because it is non – toxic, non – flammable, environmentally acceptable, inexpensive, and it leaves no solvent residue. Because of low critical temperature (31⁰C), extraction can be accomplished at a moderate temperature with minimal thermal degradation of heat labile materials. The addition of a co-solvent to the system can modify the properties of the supercritical fluid CO₂ so that higher selectivity may be achieved and more components can be extracted.

Supercritical fluid extraction (SFE) is an effective process on some pharmaceutical and cosmetic industries as it readily produces solvent free extracts [11,12,13].

2. EXPERIMENTAL PART

Oak tree' obtained lichene *Usnea barbata* L. was used as a working raw material in the experimental researching (Figure 1). This kind of lichen is widely spread in deciduous and evergreen woods. The material was gathered during a year and was kept in herbarium form, with humidity of 10.46 %. Working raw material that was use for performing of our experiments was gathered from the woods of Kozuf region, R. Macedonia. The lichen was granulated in inert area and for the experiment where in use fraction of 0.5-1.0 mm [1,6,7].

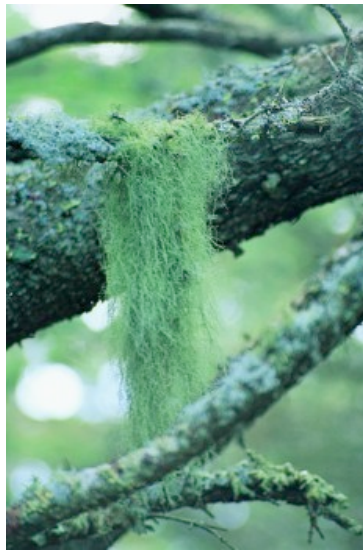

Fig. 1. Lichen Usnea barbata L.

Supercritical fluid extraction from working raw material was done in semi industrial pilot plant. The extraction apparatus used for the studies is manufactured at Uhde GmbH – Germany (Fig. 2). It is depicted schematically in Figure 3. The extractor C_1 is filled with granulated raw material which is dosed in special metallic tube. From the reservoir D_1 in which the cooled liquid CO_2 is at 50 bar pressure, the extraction fluid through F_1 filter and E_1 heat exchanger (temperature to $+5\text{ }^\circ C$) pass to the P_1 membrane pump where the pressure increases to the needful value of extraction. CO_2 is heated to the extraction temperature passing through E_2 heat exchange where the CO_2 is transformed in supercritical fluid at condition the temperature to be under the critical temperature of $31,1\text{ }^\circ C$. The supercritical fluid filling the extractor comes in contact with the raw material and dissolves the components from the raw material. With the reduction valve P_1 is set the extraction pressure, the valve P_1 is open and starts continually to pass the saturated extraction fluid through the heat exchanger E_1 , which cools the fluid to the saturation temperature in separator S_1 . The pressure in the separator is regulated with the boundary valve PV_2 , which is opened at defined pressure, not lower than 5 bar under the pressure (P_D) in the reservoir D_1 . The boundary valve PV_2 is opened to levelling of the pressures in the separator and the reservoir. After levelling of the pressures the valve PV_2 is closed, the pressure in the separator increases to the value put on the PV_2 . The fluid through the PV_2 valve passed across the F_2 filter and comes in the reservoir of CO_2 (D_1). So, the working regime of the boundary valve is bounded with the pressures: $P_{max}=PV_{2max}$ and $P_{min}=PV_{2min}$, $P_{min}>P_D$ and $P_{max}>P_{min}$. With discontinuous working of the valve PV_2 in the reservoir comes the CO_2 free of extract which remains in the separator.

The equipment has extraction and separation vessels of 4 dm^3 and 4 dm^3 in volume, respectively. Maximum working pressure is limited at 500 bar and the extraction temperature can be varied from ambient to $130\text{ }^\circ C$. The sample is loaded into extraction vessel and extracted with supercritical carbon dioxide. Pressure and temperature changes in the separation vessel cause the condensation or precipitation of the soluble components from CO_2 fluid. After

separation, CO₂ is recycled. The average mass flow rate of CO₂ is about 20 kg/h and extraction time 3 hours (Figure 3) [8].



Fig. 2. SCGE pilot plant (Uhde GmbH, Germany)

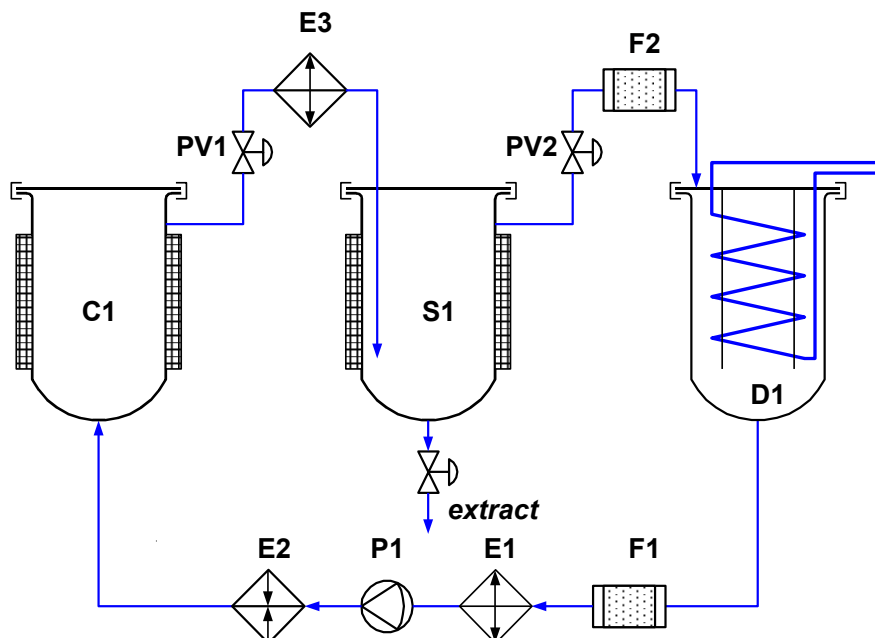

Fig. 3. Schematic flow sheet of supercritical extraction pilot plant (Uhde, Germany)
(C1 – extractor; S1 – separator; D1 – CO₂ tank)

For purification of active component to determined purity, the obtained extract was many times treated with warm 96% ethanol, in which case the result where yellow crystals which present pure usnic acid.

The extract quality (quantity of the usnic acid) is followed by applying of HPLC method, on the instrument type HP 1090, column ET 250/8/4 nucleosil C18 Machery - Nagel, mobile phase isocratic 30% 0.05 M (NH₄)₂CO₃ +70% CH₃OH at 0.5 ml/min flow rate and DAD detector (298 nm, 35 °C).

3. RESULTS AND DISCUSSION

Supercritical fluid CO₂ extraction on lichen *Usnea barbata L.*

The influence of the operating conditions (raw material' granulation, extraction fluid' flow rate, operating pressure, operating temperature and extraction time) on the yield of extract and the yield of usnic acid has been analyzed during the supercritical fluid CO₂ extraction on lichen *Usnea barbata L.* The separation process in all of the experiments was conducted at the following operating conditions: operating temperature at 25 °C and operating pressure at 50-55 bar.

Influence of the granulation of the raw material on the SFE-CO₂ process

Obtained results for the influence of the material' granulation on the yield of total extract and the yield of usnic acid are presented graphically (Figure 4):

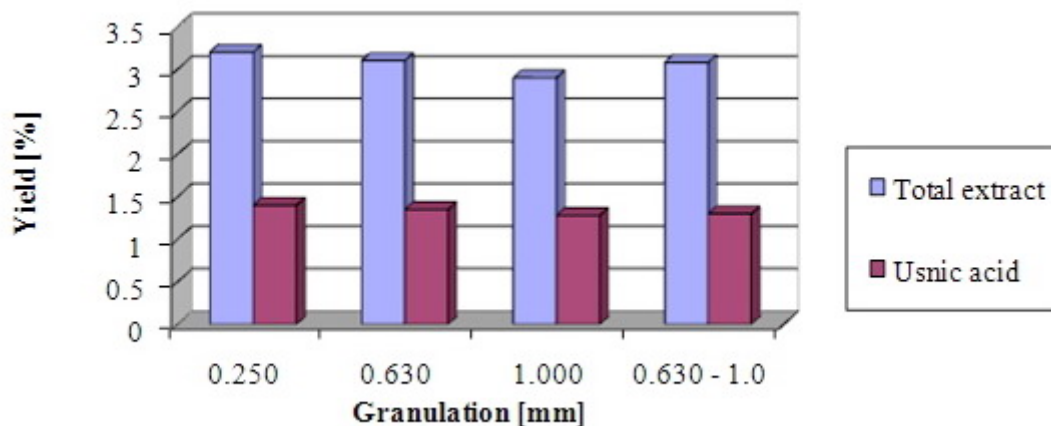

Fig. 4. Influence of lichen' granulation on SFE-CO₂ process

(Operating parameters: $P = 300$ bar; $t = 60$ °C; $Q = 20$ kg CO₂/h; 3 h; $W = 10.46\%$)

Presented results indicate that the variation of the lichen' granulation has no great influence on the yield of total extract and usnic acid. Although, at smaller granulation of the material, slightly higher values of yield were recorded which is in accordance to the Fick law of mass transfer as smaller granulation of the material provides greater mass transfer contact surface for the extraction fluid and the raw material. When analyzed systematically, going from smaller to bigger granulation as well as focusing on mixed granulation fraction, experimental results indicate a minor difference for yield percentage values. This is due to the symbiotic nature of the lichen, algae - fungus, that provides specific physical constitution. Namely, algae have a specific „threadlike” constitution and the granulating process of the lichen produces „threadlike” shaped particles that have only minor influence on the total yield at higher operating

pressure. Therefore, for all further experiments were performed by using the mixed material granulation with particle diameter of 0.630 - 1.0 mm.

Influence of operating flow rate on the SFE-CO₂ process

In order to determine the influence of the extraction agent' (CO₂) operating flow rate on the yield following experiments were conducted at constant values of operating pressure, operating temperature, extraction time and granulation while the operating flow rate of the extraction agent (CO₂) was altered in the range 10-30 kg CO₂/h.

Obtained results are given graphically (Figure 5):

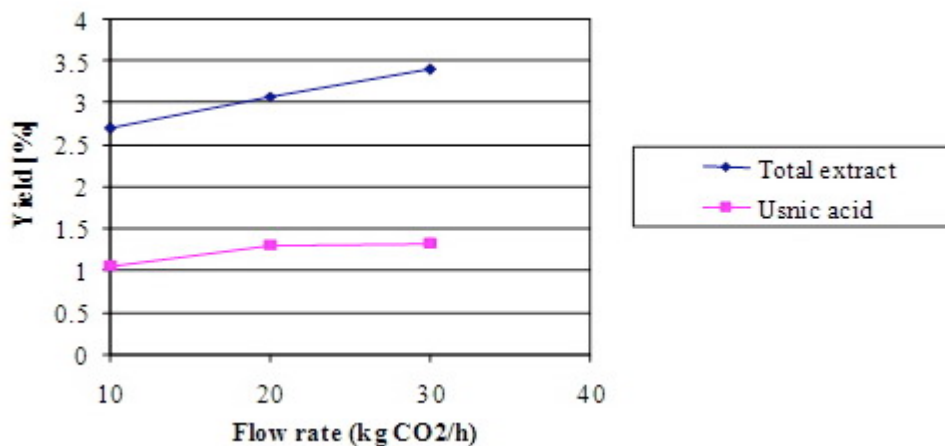

Fig. 5. Influence of operating flow rate of SFE – CO₂ fluid

(Operating parameters: $P = 300$ bar; $t = 60$ °C; 3 h; $d = 0.630$ -1.0 mm; $W = 10.46\%$)

Analysis of presented results suggests that higher operating flow rate has a positive influence on the total extraction yield. On the other hand, the positive proportional influence of the operating flow rate on the active component - usic acid' yield is only minor. Considering the main goal of the extraction process, that is obtaining higher yield values of the active component- usnic acid, further experiments were performed at a constant flow rate of supercritical CO₂ at 20 kg CO₂/h.

Influence of operating pressure on the SFE-CO₂ process

The influence of the operating pressure on the process was examined at isothermal conditions. The operating pressure of the extraction fluid was being altered in the range from 100 - 400 bar by application of the "step-wise" technique and at a constant operating temperature.

The results of these experiments are given graphically (Figure 6):

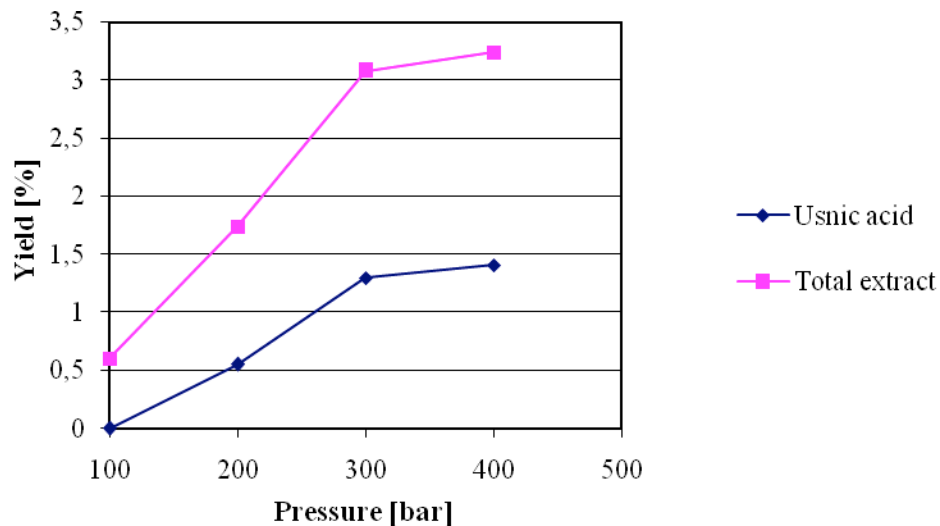

Fig. 6. Influence of operating pressure on SFE-CO₂ process
(Operating parameters: $t = 60\text{ }^{\circ}\text{C}$; 3 h; $Q = 20\text{ kg CO}_2/\text{h}$; $d = 0.630\text{-}1.0\text{ mm}$; $W = 10.46\%$)

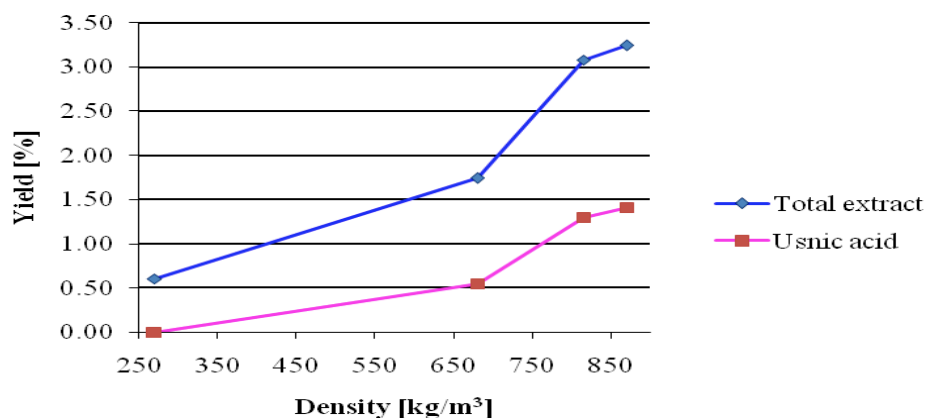

Fig. 7. Influence of the density of the supercritical fluid CO₂ on the yield of extract during SFE-CO₂ at isothermic conditions

The usnic acid extraction process begins at a pressure value higher than 100 bar. Regarding the density of the supercritical fluid, highest yield variations are achieved at a density range from 700 to 850 kg/m³ (Figure 7).

Influence of operating temperature on the SFE-CO₂ process

The influence of operating temperature on the yield of extract during SFE-CO₂ at isobaric conditions is given on Figures 8 and 9.

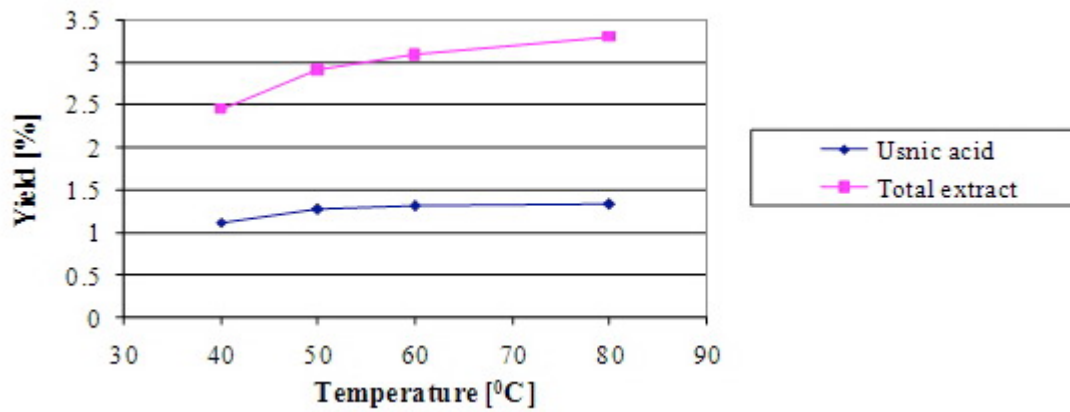

Fig. 8. Influence of operating temperature on SFE- CO_2

(Operating parameters: $P = 300$ bar; 3 h; $Q = 20$ kg CO_2/h ; $d = 0.630\text{-}1.0$ mm; $W = 10.46\%$)

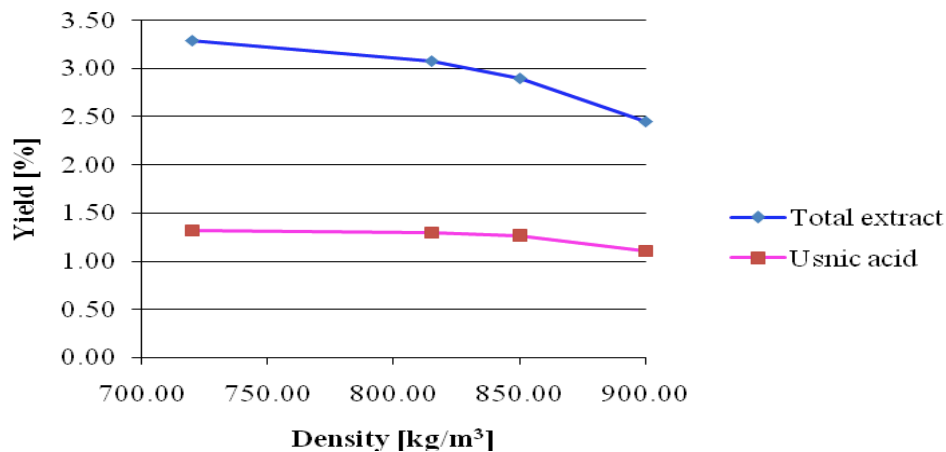

Fig. 9. Influence of the density of the supercritical fluid CO_2 on the yield of extract during SFE- CO_2 at isobaric conditions

Regarding the temperature's positive influence on the yield of usnic acid (Figure 8), the range from 40 to 60 °C is of particular importance and interest due to the fact that this positive influence is accompanied by the adequate yield increase resulting from the increase of the vapour pressure. Actually, further experiments were guided at a constant temperature of 60 °C.

During the extraction process at isobaric conditions, an increase of the operating temperature induces a significant increase of the total yield of extract. The cause of this phenomenon is not the increase of density but because of the increase of the vapour pressure (Figure 9).

Influence of extraction time on the SFE-CO₂ process

The process dynamics of the supercritical fluid CO₂ extraction on the lichen *Usnea barbata* L. is presented on Figure 10:

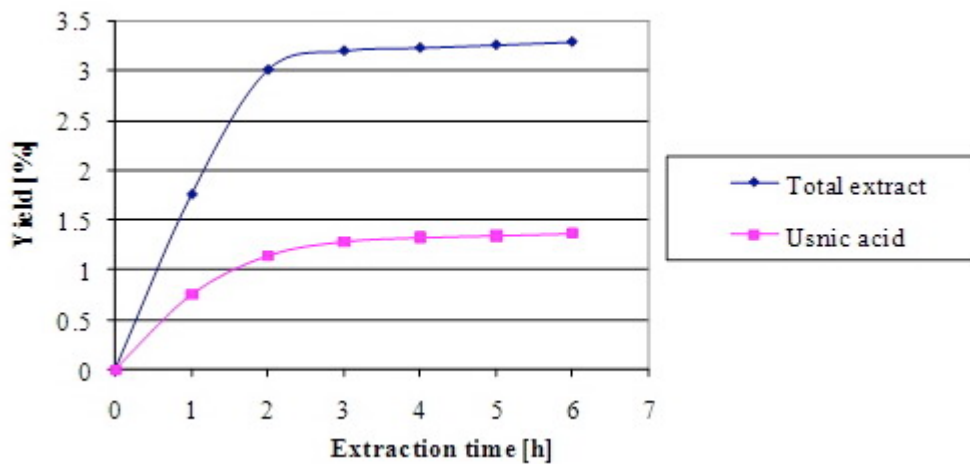

Fig. 10. Influence of extraction time on SFE-CO₂ process

(Operat. parameters: $P = 350$ bar; $t = 60$ °C; $Q = 20$ kg CO₂/h; $d = 0.630$ - 1.0 mm; $W = 10.46$ %)

The functional dependency of total yield and the usnic acid' yield from the extraction time (Figure 10) presents the supercritical extraction process dynamics. The interpretation of the results indicates a desired range from 3 to 4 hours, as the process enters equilibrium state.

In the frames of this investigation, liquid CO₂ was used as extraction fluid, but the yield values for usnic acid are very low compared to the SFE-CO₂ extraction process. That results due to the low solubility of usnic acid in liquid CO₂.

The isolated and purified usnic acid from the lichen *Usnea barbata* L., can be used in cosmetic products as a natural antibiotic. In perfume industry' functional products, usnic acid can be applied as Na-usneate, a salt that is also a natural antibiotic.

Process parameters' legend:

Q - Supercritical CO₂ flow rate [kg/h]

W - Raw material humidity [% wt]

d - Particle granulation [mm]

τ - Extraction time [h]

4. CONCLUSION

Appropriate interpretation and analysis of the experimentally obtained results provide the following conclusions:

- By supercritical fluid extraction of usnic acid from oak tree *Usnea barbata* L. Lichen, highest yield values (up to 56% mass) were achieved at a operating pressure of 300 bar, operating temperature at 60 °C and extraction time of 3 h.

- At operating temperature of 40 °C and lower pressure values, extraction agent' density is much higher hence providing greater solubility capacity. On the other hand, the usnic acid has higher vapour pressure values at higher temperatures and therefore higher solubility at higher temperatures. Accordingly, this contradicts the extraction fluid (CO₂) density at lower pressure values. It can be concluded that the extraction process should be performed “deep” in the supercritical region, at temperature and pressure values exceeding 60 °C and 300 bar;
- Obtained results regarding usnic acid extraction yield, extracted from *Usnea barbata* L., are clearly indicating the significant advantage of the supercritical extraction process over the classic solid-liquid extraction process, where a maximal yield value obtained by application of ethanol as an extraction agent, is only 27.22% mass.

REFERENCES

- [1] K. Lisichkov, Separation of active components from lichen flora by application of supercritical fluid extraction, PhD Thesis, Fac. of tech. and metall., Skopje, 2002
- [2] V. Ahmadjian, E.H. Mason, *The Lichens*, Academic Press, New York and London, 1973
- [3] J. Brash, P. Jacobsen, *Alergologie*, 1991, 14, 99
- [4] C.R. Bhupesh et al., *Int. Journal of Food Sci. and Tech.*, 1996, 31, 137
- [5] C.F. Culberson, J.A. Elix, *Lichen substances*, Academic Press, London, 1989, p. 509
- [6] E. Daugsas et al., *J. Agric. Food. Chem.*, 1998, 46, 4347
- [7] B. Ribar, Z. Djarmati et al. *J. Crystall. Spectr. Research*, 1993, 23-2, 107
- [8] B. Lisichkov, Model development for design and optimization of mass transfer performances with simulation of high pressure extraction, Master thesis, Faculty of Technology and Metallurgy, Skopje, Macedonia, 2007.
- [9] R. Santos, T. Lu, L. Schlieper, M. B. King, J. Bastos, Extraction of useful components from herbs using supercritical CO₂: experimental findings and data modelling, 3rd International Symposium On high-pressure engineering; von Rohr, Ph. R., Trepp, Ch., Eds.; Elsevier: Amsterdam; (1996) p 399,
- [10] E. Reverchon, I. De Marco, *Supercritical fluid extraction and fractionation of natural matter*, *J. Supercrit. Fluids* 38 (2), (2006) 146–166,
- [11] J.M. del Valle, J.C. de la Fuente, D.A. Cardarelli, Contributions to supercritical extraction of vegetable substrates in Latin America, *J. Food Eng.* 67 (1/2), (2005)35–57,
- [12] E. Reverchon, C. Marrone, Modeling and simulation of the supercritical CO₂ extraction of vegetable oils, *J. Supercrit. Fluids* 19 (2), (2001) 161–175,
- [13] T.H.J. Beveridge, B. Girard, T. Kopp, J.C.G. Drover, Yield and composition of grape seed oils extracted by supercritical carbon dioxide and petroleum ether: varietal effects, *J. Agric. Food Chem.* 53 (5),(2005), 1799–1804.

NADKRITIČNA EKSTRAKCIJA FLUIDA CO₂ IZ LIŠAJA *Usnea barbata* L.

Kiril Lisichkov, Stefan Kuvendziev
klisickov@yahoo.com

*Faculty of Technology and Metallurgy, University "Ss. Cyril and Methodius",
Skopje, R. Macedonia*

Izvod

*Nekonvencionalni postupak separacije –superkrična ekstrakcija fluida CO₂ (SFE-CO₂) je u skladu sa strogim zahtevima preciznih procesnih eko-tehnologija. On predstavlja perspektivan metod naročito u dobijanju ekološki čistih ekstrakta iz biljnih i životinjskih sirovina. Uticaj radnih parametara (granulacija sirovine, brzina protoka fluida ekstrakcije, radni pritisak, radna temperature i vreme ekstrakcije) na prinos ekstrakta i usninske kiseline je proučavan kroz process ekstrakcije na *Usnea barbata* L., primenom nadkričnog CO₂ (SFE-CO₂). Proces separacije u svim eksperimentima je izvršen na radnoj temperaturi od 25 °C i pri radnom pritisku od 50-55 bara. Ekstrakcija aktivnih komponenata iz lišaja putem nadkričnog CO₂ je izvršena u pilot postrojenju za ekstrakciju za procesuiranje čvrstih sirovina na visokom pritisku.*

Ključne reči: SFE-CO₂, usninska kiselina, lišaj.

